

UDDEHOLM COMPONENT BUSINESS

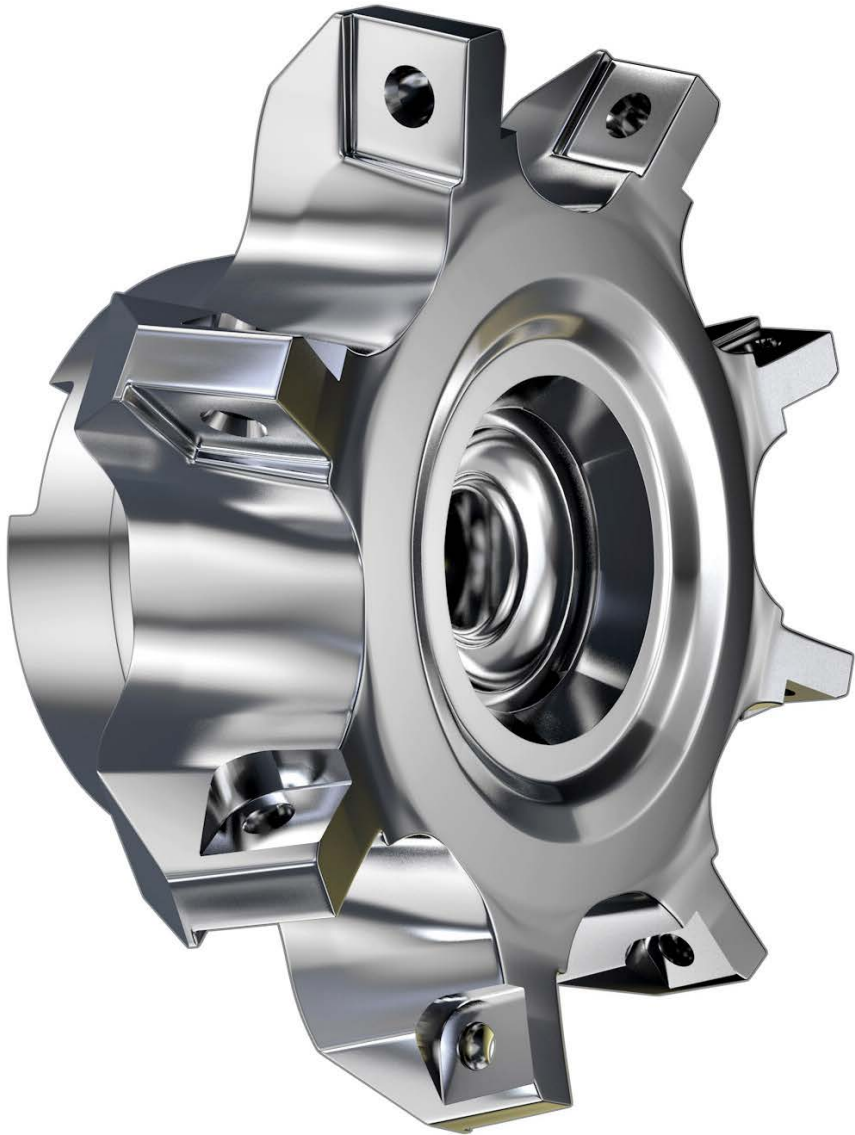

© UDDEHOLMS AB

No part of this publication may be reproduced or transmitted for commercial purposes without permission of the copyright holder.

This information is based on our present state of knowledge and is intended to provide general notes on our products and their uses. It should not therefore be construed as a warranty of specific properties of the products described or a warranty for fitness for a particular purpose.

Classified according to EU Directive 1999/45/EC

For further information see our "Material Safety Data Sheets".

Edition: 3 03.2014

The latest revised edition of this brochure is the English version, which is always published on our website www.uddeholm.com



SS-EN ISO 9001
SS-EN ISO 14001

Selecting a steel supplier is a key decision for all parties. The component business value chain comprises of component manufacturers, machine manufacturers, component users and end users. Thanks to superior material properties, Uddeholm's customers get reliable tools and components. Our products are always state-of-the-art, consequently, we have built a reputation as the most innovative tool steel producer in the world.

Uddeholm produces and delivers high quality Swedish tool steel to more than 100,000 customers in over 100 countries. Some markets are served by ASSAB, our exclusive sales channel in the Asia Pacific area. Together we secure our position as a world leading supplier of tool steel.

Wherever you are in the manufacturing chain, trust Uddeholm to be your number one partner and tool steel provider for optimal production economy.

Quite simply, it pays to go for a better steel.

CONTENTS

Introduction	4
Improved profitability with Uddeholm tool steel	4
Less downtime and higher strength	5
Higher wear resistance—longer life span	6
Withstanding wear at high temperatures	7
Corrosive environments demand high quality	8–9
Product programme	
– Description and applications	10
– Chemical composition	11
– Properties	12

Introduction

Achieving the best results takes time and dedication. It all boils down to carefully selecting the right material to work with during every step in the production process and in every single component. Having Uddeholm as a partner will enable you to find new cost-effective solutions. We are happy to be your partner throughout the whole process—from the initial ideas through to the finished product. Uddeholm is a world-leader in developing and manufacturing tool steel. Using our tool steel in finished components, a concept we choose to call Uddeholm Component Business, produces better results and a longer life span.

Improved profitability with Uddeholm tool steel

Uddeholm Component Business offers a solution where the first class tool steel of Uddeholm comes to use in components and applications where conventional engineering and stainless steel provide an insufficient solution.

The qualities of tool steel contribute to an optimized design, increased performance, lower maintenance costs and the best overall economy. A high proportion of these costs can be avoided when selecting a steel grade with better material properties.

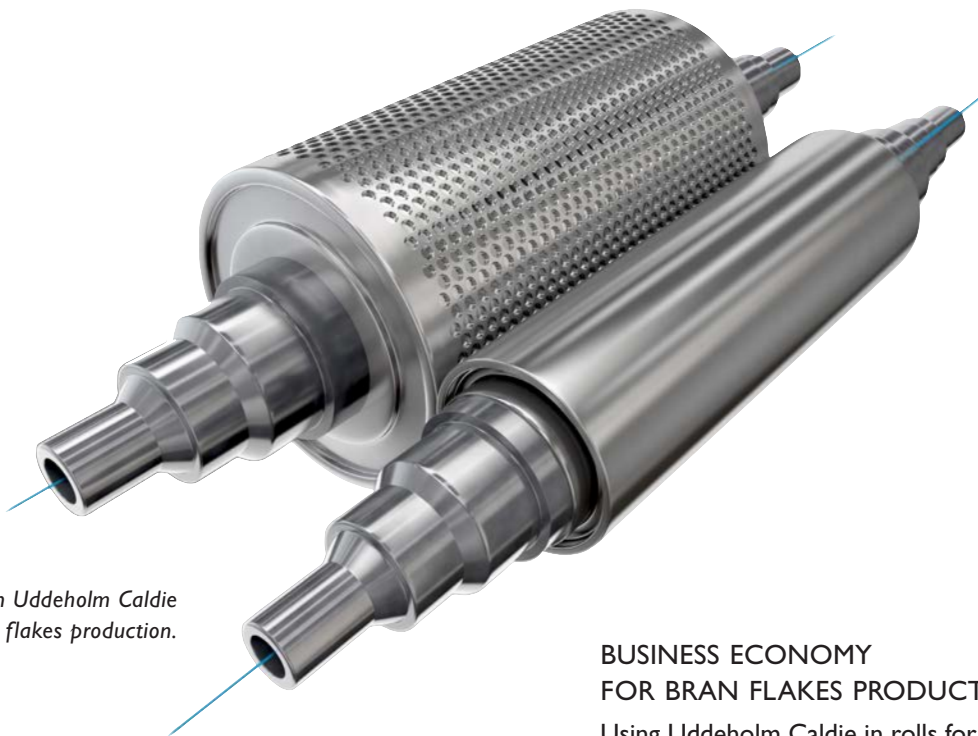

Rolls in Uddeholm Caldie for Bran flakes production.

BUSINESS ECONOMY FOR BRAN FLAKES PRODUCTION

Using Uddeholm Caldie in rolls for Bran flakes production gives lower production and maintenance costs.

A customer used A2 material in the rolls. This resulted in 500 production hours and eight production stops per year. By instead selecting Uddeholm Caldie, the production time increased to 1800 hours and only two stops per year.

Selecting Uddeholm tool steel gives the best production economy.

Uddeholm Component Business applications and components can be found within any industry where there are high demands on properties such as wear resistance, strength, corrosion and heat resistance.

Less downtime and higher strength

When it comes to comparing the strength of different steel grades it is soon evident that Uddeholm's tool steel show far better strength values compared to engineering steel grades. The advantage here is that the adaptive hardness of the material through quenching and tempering can be exploited according to specific demands. High fatigue strength can be achieved when combining the high strength and cleanliness of the steel. Uddeholm's ESR grades are good example of this. This means a longer life for the finished component and these properties also enable weight reductions, which lead to lower costs and higher performance.

Teams, in for example rally cross and circuit racing, have for many years been using drive shafts from different retailers who have chosen Uddeholm Orvar Supreme as material for their superior products.



Drive shafts for motor sport made from Uddeholm Orvar Supreme.

STRENGTH/HARDNESS FOR DIFFERENT STEEL GRADES

STRENGTH

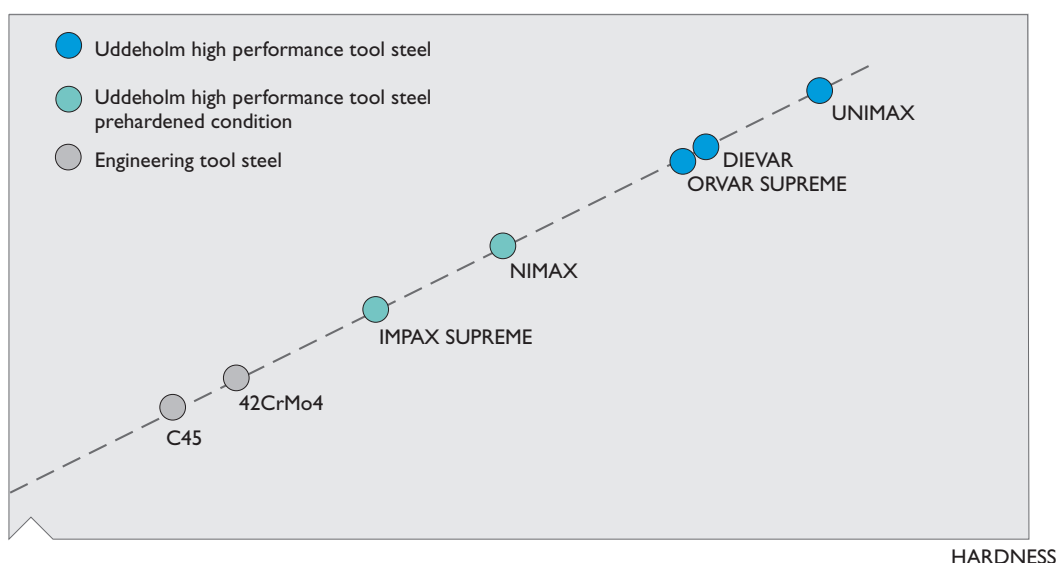

Higher wear resistance— longer life span

Wear costs industrial companies a lot of money every year largely due to abrasion. Within this area the key is to optimize strength and abrasion resistance. Uddeholm's product range includes steel grades with a high level of combined durability and toughness. Certain grades for cold work tools are especially well suited to withstand wear due to their structure containing hard phase particles.

STEEL WHEEL USING UDDEHOLM IMPAX SUPREME

Normally wheels, which go with low speed and high load, are manufactured in cast iron. When changing materials in the wheels of a load car from cast iron to Uddeholm Impax Supreme, with a nitrided surface, a cost reduction of approximately 60% was achieved due to a radically increased life span of the wheels.

Uddeholm Impax Supreme was supplied at 310 HB and the nitrided surface layer had a thickness of 0.4 mm and a hardness of 750 Hv.

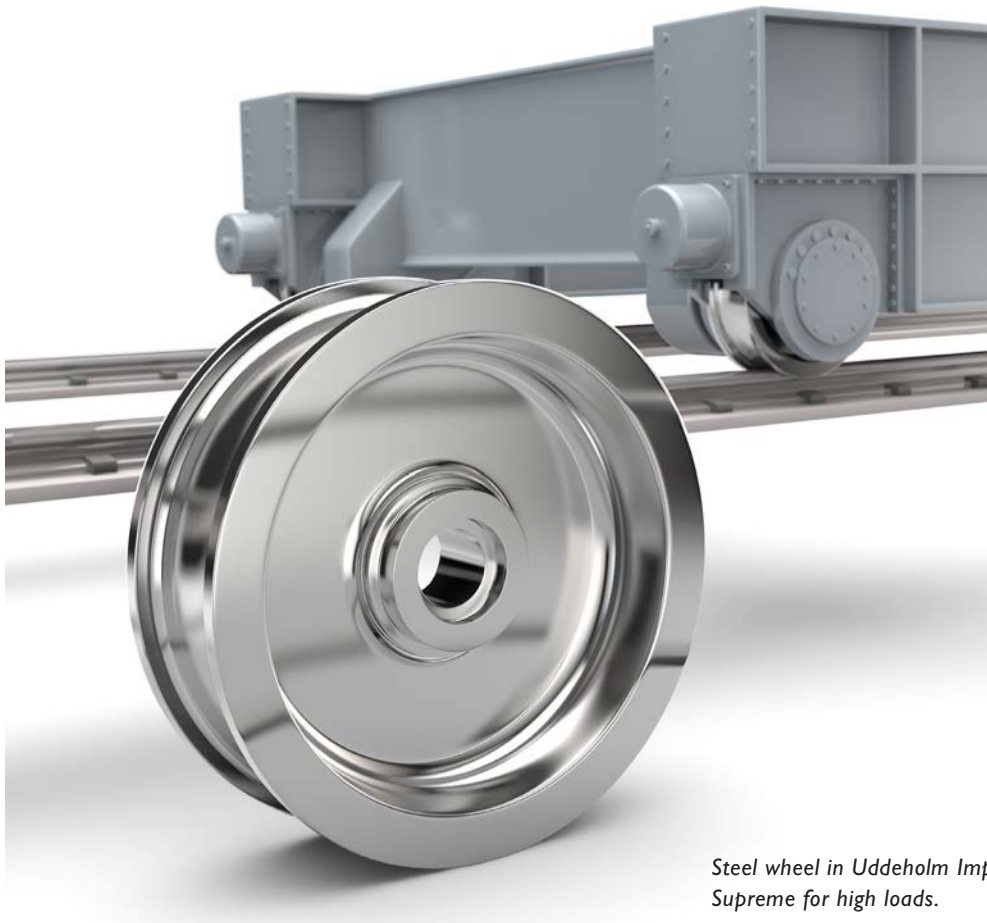

Steel wheel in Uddeholm Impax Supreme for high loads.

Withstanding wear at high temperatures

Uddeholm's steel grades are also used in hot forging tools and consequently developed to withstand high temperatures. This property means major improvements in strength for parts that are exposed to heat during a long period of time, i.e. they are not losing strength and hardness as often in the case for engineering steel due to tempering back.

KNIFE FOR CUTTING OF HOT STEEL BILLETS WITH UDDEHOLM UNIMAX

Uddeholm Unimax is perfectly suited for the cutting of hot steel billets.

The billets cut in this case are approximately 1000°C (1830°F) and made of the steel grade C45. The knife cuts at a speed of 120 cuts/hour. Originally, the knives were manufactured in W.-Nr. 1.2343 with a hardness of 52–54 HRC. These knives could perform 43 000 cuts before they needed to be changed. The knives wore out due to chipping and cracking.

The solution was knives in Uddeholm Unimax at 56 HRC. The life time was extended to 150 000 cuts. No more problems with cracking have appeared after this change.



*Knives in Uddeholm Unimax
for billet cutting.*

Corrosive environments demand high quality

Uddeholm's range of corrosion resistant steel, often used for plastic moulds, provides a unique combination of strength, corrosion resistance and durability, which enable brand new technical design solutions. This means that components do not need to be surface treated and the material can be used in environments where corrosion would normally be an issue.

CAR BATTERY FRAGMENTATION USING UDDEHOLM STAVAX ESR

A car battery recycling company had poor lifetime of their knives. The reason for that was that the acid in the batteries together with caustic soda caused heavy corrosion, which resulted in cracks and total breakage of the knives.

A change of steel grade from X155CrVMo12-1 (D2) to Uddeholm Stavax ESR resulted in a dramatically increased lifetime, from 2 days to 6 weeks.

Before the change in materials the customer was afraid that the knives would break and cause accidents. Now he feels safe with the knives, can reach higher profits and experience, much lower maintenance costs and downtime.



Car battery recycling knives in Uddeholm Stavax ESR.

FEEDING AGERS FOR MEAT GRINDING IN UDDEHOLM CORRAX

The machine is designed for grinding of both fresh and frozen meat down to -20°C .

Many components in the machine are made of stainless steel. One of the feeding agers is made of Uddeholm Corrax, which is part of the Uddeholm Stainless Concept.

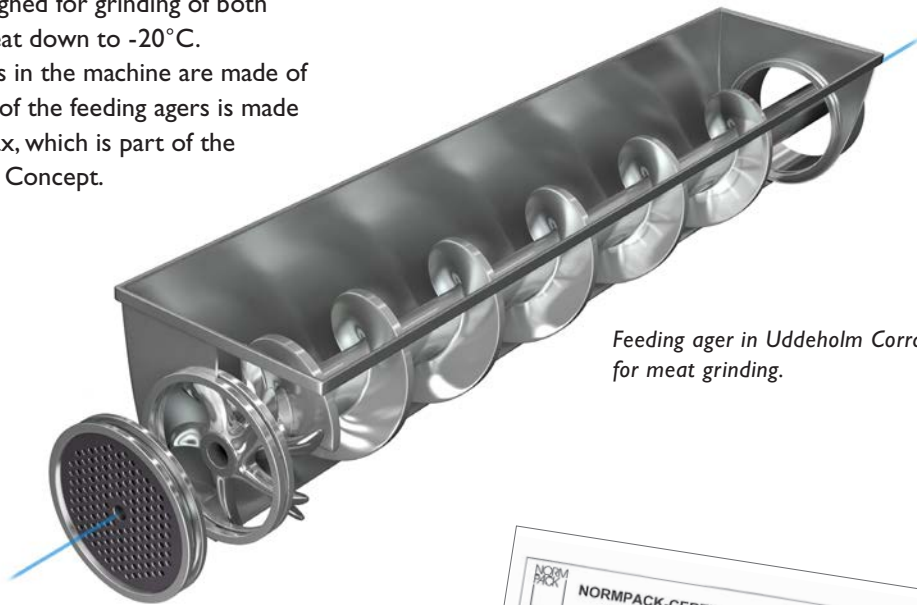

Feeding ager in Uddeholm Corrax for meat grinding.

Uddeholm Corrax provides a number of advantages:

- high strength of a stainless steel
- optimal combination of corrosion resistance and wear resistance
- high ductility and toughness
- welding benefits, the coil is welded to the core (axis) and both elements are made of Uddeholm Corrax
- less downtime
- less maintenance costs
- a multiplied life span of the component



UDDEHOLM STEEL GRADES CERTIFIED BY NORMPACK

For the requirements in the food industry some of Uddeholm tool steel grades are certified according to the European Union legislation (1935/2004).

Materials can be certified for the following areas:

- dry food
- acid food
- alcoholic food
- fatty food



EU symbol, which shows that a material complies with the requirements for food contact.

The Normpack norm includes and fulfills the European Union framework legislation regarding materials that come into contact with food.

Product programme

DESCRIPTION/APPLICATIONS

UDDEHOLM TOOL STEEL IMPAX SUPREME	A prehardened Ni-Cr-Mo-steel supplied at 310 HB with good nitriding and induction hardening properties. Suitable for shafts, pistons, machine components for medium and high stress.
NIMAX	Excellent toughness, machinability and weldability. Suitable for shafts, pistons, machine components for medium and high stress.
RAMAX HH ROYALLOY	Prehardened stainless steel with good machinability, high tensile strength and good corrosion resistance. Suitable for machine parts in corrosive environments.
MIRRAX ESR	A through-hardened corrosion resistant steel. Suitable for machine parts in corrosive environments.
ELMAX SUPERCLEAN	A corrosion resistant PM steel for parts subject to wear in corrosive environments.
CORRAX	A steel with exceptionally good corrosion resistance and good weldability. Suitable for machine parts for high stress which demand high toughness at low temperatures, also suitable for corrosive environments.
STAVAX ESR	Through-hardened corrosion resistant steel. Suitable for machine parts in corrosive environments.
BURE	Good toughness, ductility and hardening properties. Recommended for machine parts and shafts requiring extensive swarf removal and high yield point.
ORVAR SUPREME	A steel with good wear resistance, suitable for machine parts and shafts requiring a high yield point and fatigue strength.
DIEVAR	Good high temperature strength and excellent hardenability, toughness and ductility. Suitable for machine parts and shafts requiring a high yield point and fatigue strength.
UNIMAX	A steel with a unique combination of toughness and wear resistance. Suitable for machine parts and shafts requiring a high yield point and fatigue strength.
CALDIE	Good chipping, cracking and wear resistance. Suitable for machine parts for high stress.
SLEIPNER	A steel with good wear resistance, chipping resistance and hardenability. Suitable for wear parts with high abrasive wear.
VANADIS 6 SUPERCLEAN	A PM steel with high wear resistance and good chipping resistance and compressive strength. Suitable for wear parts subject to extremely high wear.
BALDER	Machine parts for high stress which demand high toughness, also for parts where high temperature strength is required.

CHEMICAL COMPOSITION

UDDEHOLM TOOL STEEL	AISI	ANALYSIS %							Others
		C	Si	Mn	Cr	Mo	Ni	V	
IMPAX SUPREME	P20 modified 1.2738	0.37	0.3	1.4	2.0	0.2	1.0		
NIMAX		0.1	0.3	2.5	3.0	0.3	1.0		
ROYALLOY	(420F)	0.05	0.4	1.2	12.6			S 0.12	+N +Cu
RAMAX HH		0.12	0.2	1.3	13.4	0.5	1.6	0.2	S 0.1 +N
MIRRAX ESR	420 modified	0.25	0.3	0.5	13.3	0.3	1.3	0.3	+N
ELMAX SUPERCLEAN		1.70	0.8	0.3	18.0	1.0		3.0	
CORRAX		0.03	0.3	0.3	12.0	1.4	9.2		Al 1.6
STAVAX ESR	420 modified	0.38	0.9	0.5	13.6			0.3	
BURE		0.39	1.0	0.4	5.3	1.3		0.9	
ORVAR SUPREME	H13 (1.2344)	0.39	1.0	0.4	5.2	1.4		0.9	
DIEVAR		0.35	0.2	0.5	5.0	2.3		0.6	
UNIMAX		0.50	0.2	0.5	5.0	2.3		0.5	
CALDIE		0.70	0.2	0.5	5.0	2.3		0.5	
SLEIPNER		0.90	0.9	0.5	7.8	2.5		0.5	
VANADIS 6 SUPERCLEAN		2.10	1.0	0.4	6.8	1.5		5.4	
BALDER		0.30	0.3	1.2	2.3	0.8	4.0	0.8	

PROPERTIES

UDDEHOLM TOOL STEEL	DELIVERY HARDNESS ~HB	RECOMMENDED HARDNESS HRC	YIELD STRENGTH Rp0.2 (Mpa)	TENSILE STRENGTH (Mpa)
IMPAX SUPREME ¹⁾	310	33	900	1000
NIMAX ¹⁾	380	40	785	1265
ROYALLOY ¹⁾	310	33	890	1070
RAMAX HH ¹⁾	340	37	990	1140
MIRRAX ESR	250	50	1290	1780
ELMAX SUPERCLEAN	250	58	2200	2900
CORRAX	330	46	1400	1500
STAVAX ESR	190	50	1460	1780
BURE	180	42	1200	1400
ORVAR SUPREME	180	48	1350	1600
DIEVAR	160	50	1470	1770
UNIMAX	185	56	1780	2150
CALDIE	215	60	2350 ²⁾	–
SLEIPNER	235	60	2350 ²⁾	–
VANADIS 6 SUPERCLEAN	255	62	2530 ²⁾	–
BALDER ¹⁾	420	44	1230	1440

¹⁾ Pre-hardened

²⁾ Compressive strength

Further information

Further information about the Uddeholm steel grades, the mechanical properties in hardened condition, heat treatment recommendations, cutting data recommendations and product brochures for each steel grade can be found on our website www.uddeholm.com/downloads

For the requirements in the food industry some of the Uddeholm steel grades are certified by Normpack. The certificate can be found on our website: [www.uddeholm.com/products/steel for components](http://www.uddeholm.com/products/steel%20for%20components)

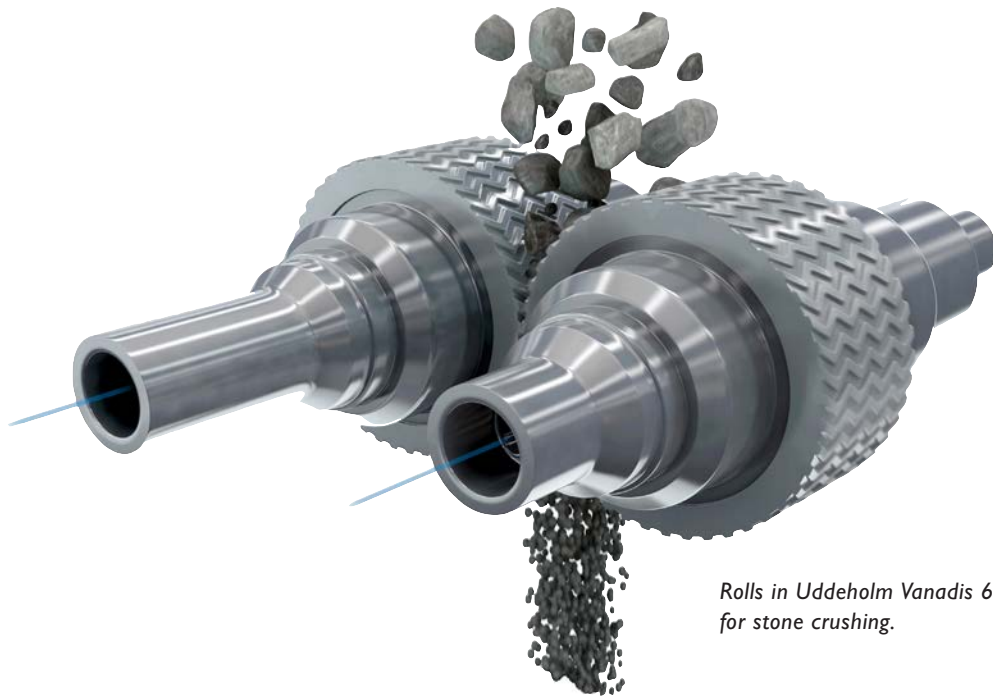

*Rolls in Uddeholm Vanadis 6 SuperClean
for stone crushing.*

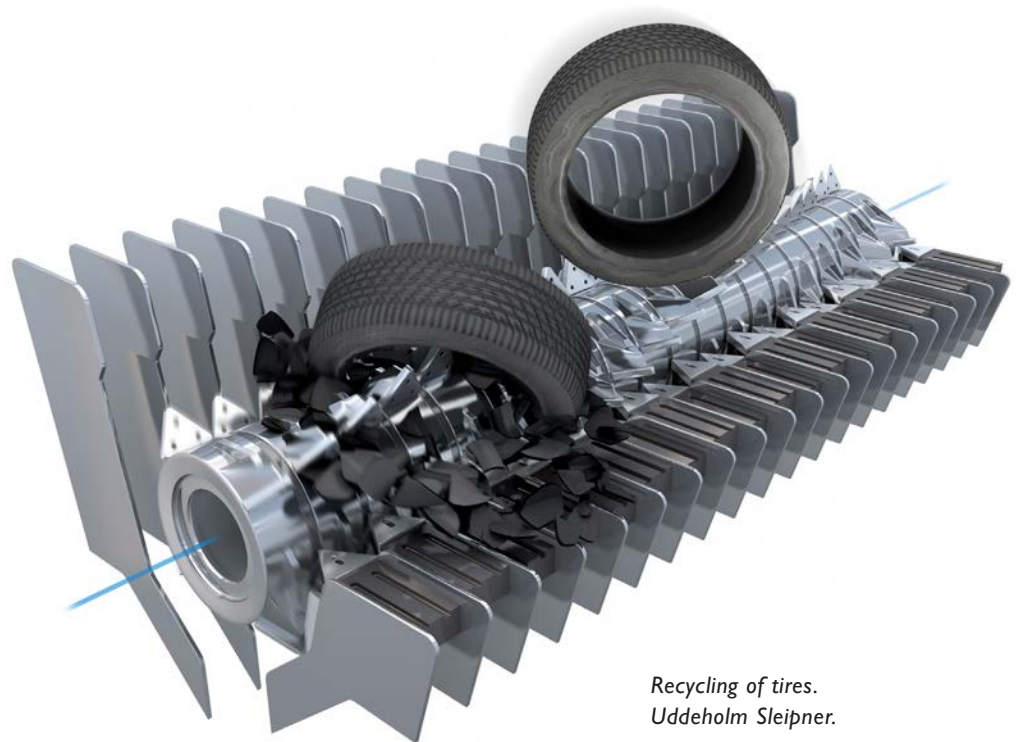

*Recycling of tires.
Uddeholm Sleipner.*



*Drill bodies in Uddeholm Bure.
©Photo from AB Sandvik Coromant.*



*Disc brake hub made from
Uddeholm Balder steel.*

*Diesel injection nozzles in
Uddeholm Vanadis 4 Extra
SuperClean.*

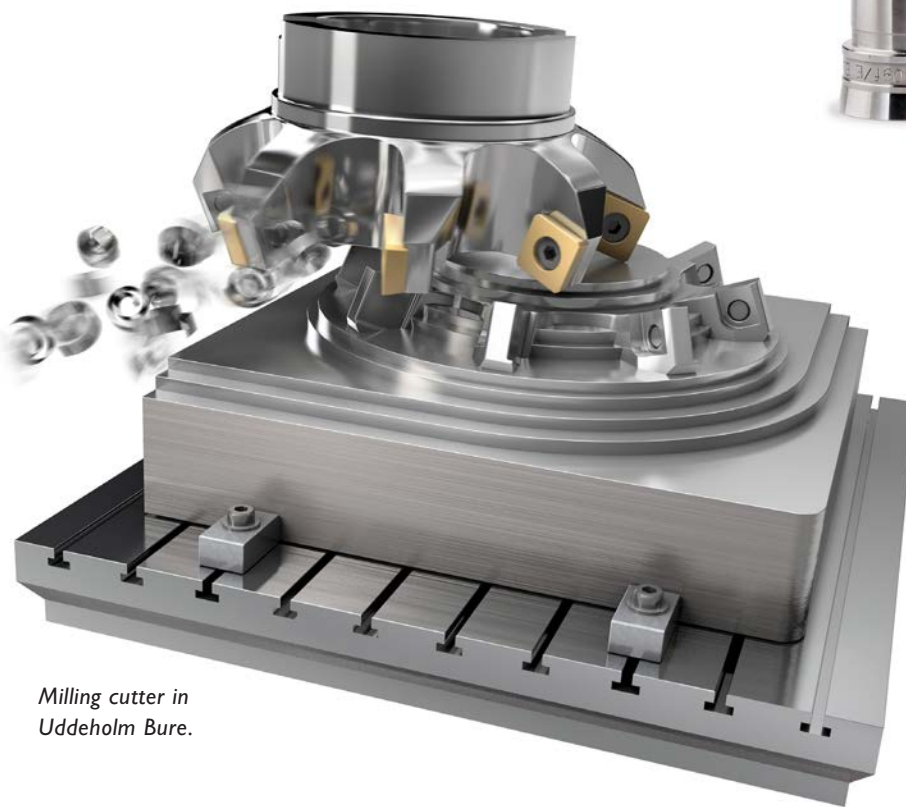

*Milling cutter in
Uddeholm Bure.*



Network of excellence

UDDEHOLM is present on every continent. This ensures you high-quality Swedish tool steel and local support wherever you are. ASSAB is our exclusive sales channel, representing Uddeholm in the Asia Pacific area. Together we secure our position as the world's leading supplier of tooling materials.

UP
 WOR
 TRUST IS SOM
 TRUST IS I
 AUTOMOTIVE
 LEADING SU
 TOUGHNESS ST
 MATERIALS
 TOOLING WATER
 UNDERSTAND
 RESULTS IN
 CUSTOMER B
 RELIABILITY TRUST IS
 AUTOMOTIVE
 LEADING SU
 INNOVATION
 STRENGTH INNOVATION
 WORLDWIDE PRE
 SOMETHING YO
 PROBLEM
 THE WORL
 NOMY THE
 DUCTILITY TO
 COMMITMENT PART
 KNOWLEDGE UN
 KNOWLEDGE
 RELIABI
 OF EXCEL
 AUTOMOTIVE A
 ECONOMY THE
 TOTAL ECONOMY
 DUCTILITY TOUGHNE
 HARDEST WORLWI
 TRUST IS SOMETH
 UNDERSTANDING MACHIN
 RESULTS SOLVING PROB
 ECONOMY THE WORL
 STRENGTH IN
 TOUGHNESS STRENGTH I
 UNDERSTANDING MACHIN
 UNDERSTANDING MACHIN
 RELIABILITY RELIABILITY RESU
 LASTING TOOLS TOTAL
 YOU EARN, EVERY DAY. LO
 OF THINKING HIGH PE
 OF TOOLING MATERIALS C
 INNOVATION KNOWLEDGE
 BE STRENGTH INNOVATION KNOW
 PRESENCE LONG DURABILITY
 TRUST IS SOMETHING YOU EARN,
 PROBLEMS AUTOMOTIVE

UDDEHOLM is the world's leading supplier of tooling materials. This is a position we have reached by improving our customers' everyday business. Long tradition combined with research and product development equips Uddeholm to solve any tooling problem that may arise. It is a challenging process, but the goal is clear— to be your number one partner and tool steel provider.

Our presence on every continent guarantees you the same high quality wherever you are. ASSAB is our exclusive sales channel, representing Uddeholm in the Asia Pacific area. Together we secure our position as the world's leading supplier of tooling materials. We act worldwide, so there is always an Uddeholm or ASSAB representative close at hand to give local advice and support. For us it is all a matter of trust—in long-term partnerships as well as in developing new products. Trust is something you earn, every day.

For more information, please visit www.uddeholm.com, www.assab.com or your local website.